

PUREM BY EBERSPÄCHER / PRODUCT PORTFOLIO

INNOVATION IS OUR KEY – TO CLEAN AND QUIET MOBILITY

Components and systems for all vehicle classes
to meet global emission standards

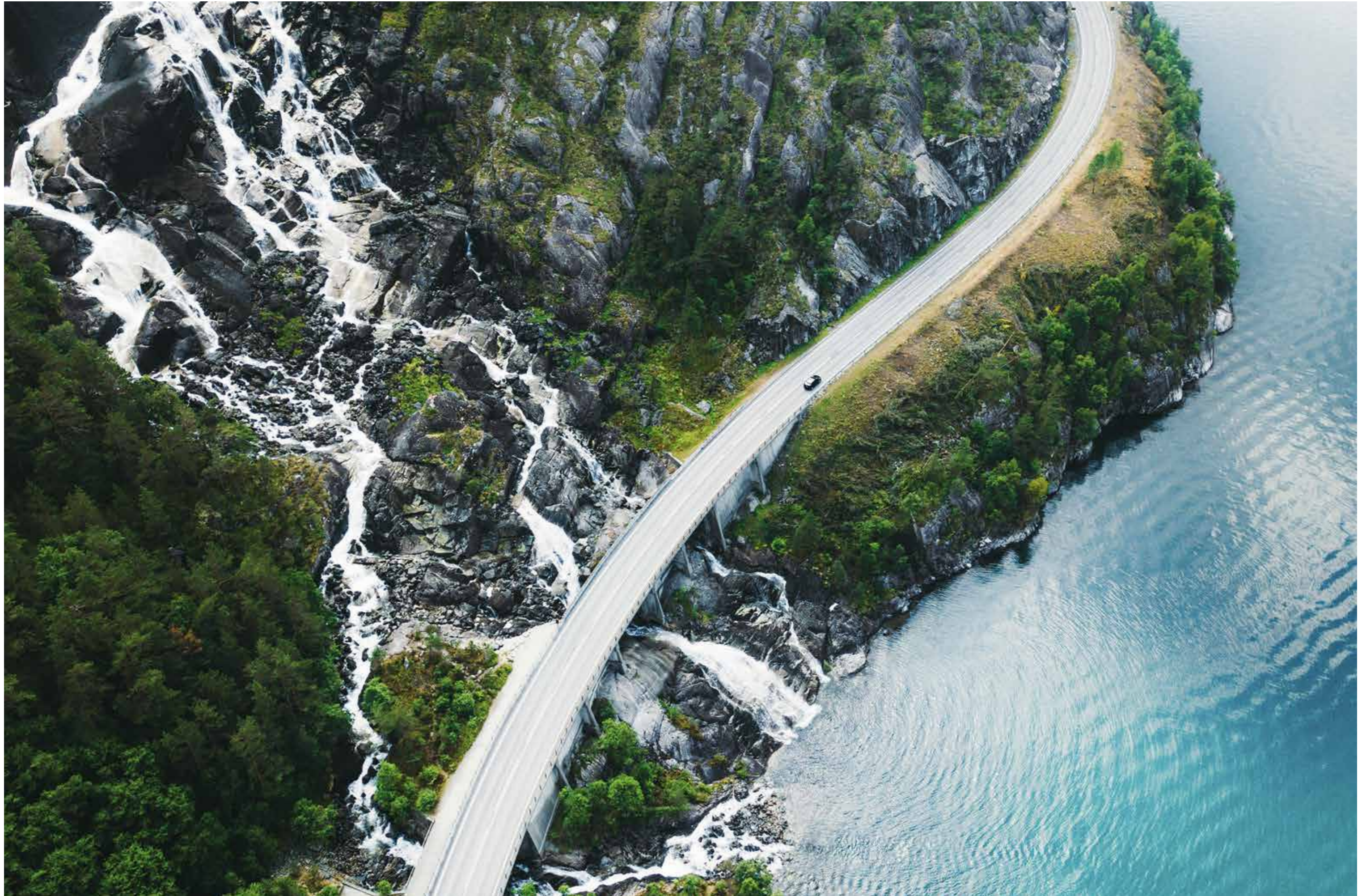



THE EBERSPÄCHER GROUP

 **28** countries

 **10,000** employees

 **80** locations

 **4.9** billion euros in total sales

 Headquarters:
Esslingen, Germany

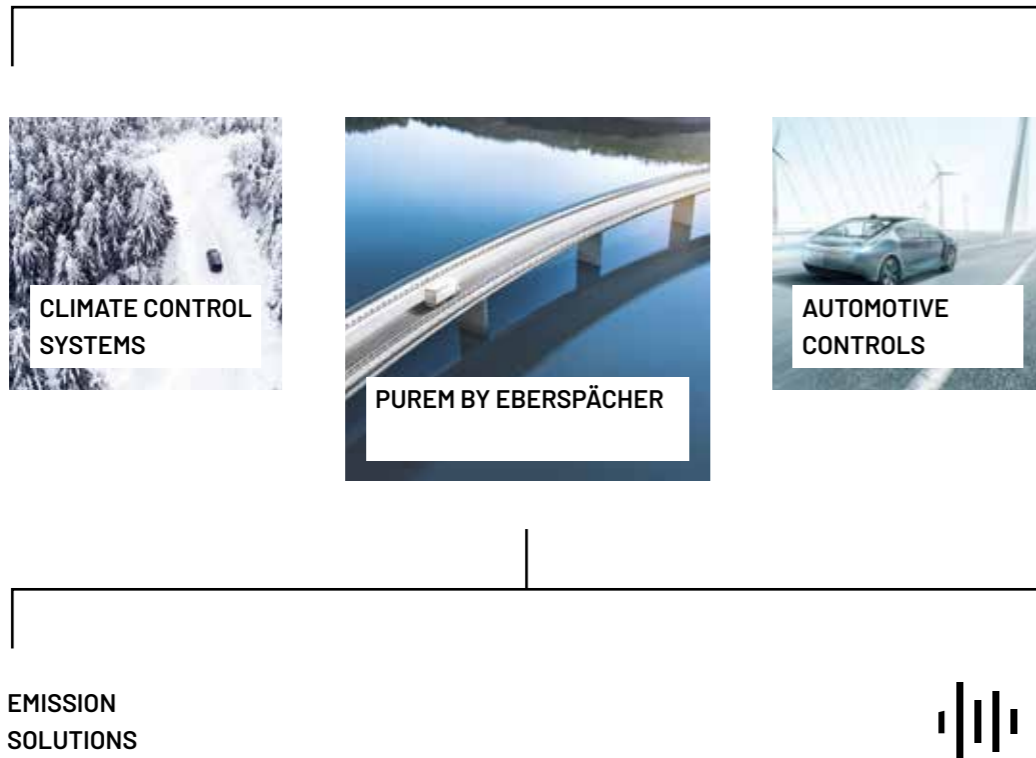

EXPERTS IN EMISSIONS AND ACOUSTICS

FOR THE MOBILITY OF THE FUTURE

The best solution for the customer.

With exhaust systems featuring state-of-the-art technology, we are making a significant contribution to the clean and quiet mobility of the future – across all vehicle classes.

In the development and production of our exhaust systems and components, we attach great importance to resource-saving and sustainable overall processes. In doing so, we work with state-of-the-art development and production methods. This results in highly innovative products that provide vehicle manufacturers worldwide with the highest level of quality and reliability.

This makes Purem by Eberspächer a reliable and technologically expert partner when it comes to efficient solutions for complying with statutory emission and acoustic limits. Today, Purem by Eberspächer is making a significant contribution to ensuring that tomorrow's vehicles comply with or even fall below the upcoming requirements.

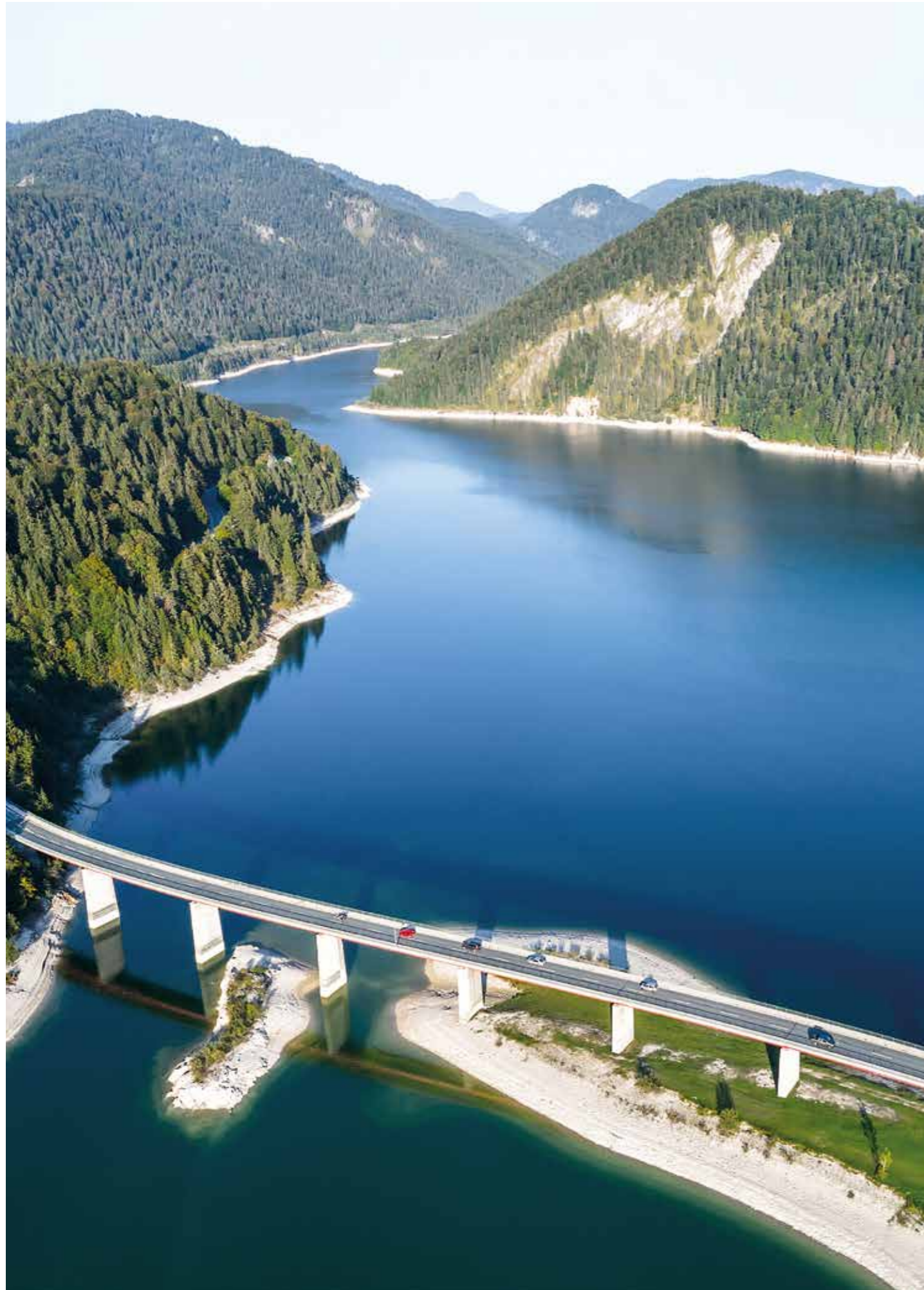

EMISSION SOLUTIONS – “MISSION ZERO”

To comply with future emissions legislation, innovative solutions are needed to further reduce emissions from passenger cars and commercial vehicles with internal combustion engines. The exhaust emission limits for various pollutants, which must be followed under all driving conditions, are being further tightened. Expanded and more stringent test conditions are also presenting vehicle manufacturers with new challenges.

Combating climate change is a global responsibility. To achieve the climate targets set, concepts and solutions for further CO₂ reduction are required in the mobility sector.

In the area of Emission Solutions, Purem by Eberspächer has identified its key strategic areas of action: Low Temperature Emissions, High Temperature Emissions, Urea Processing and CO₂ Reduction. These make a significant contribution to meeting the “Mission Zero” target.

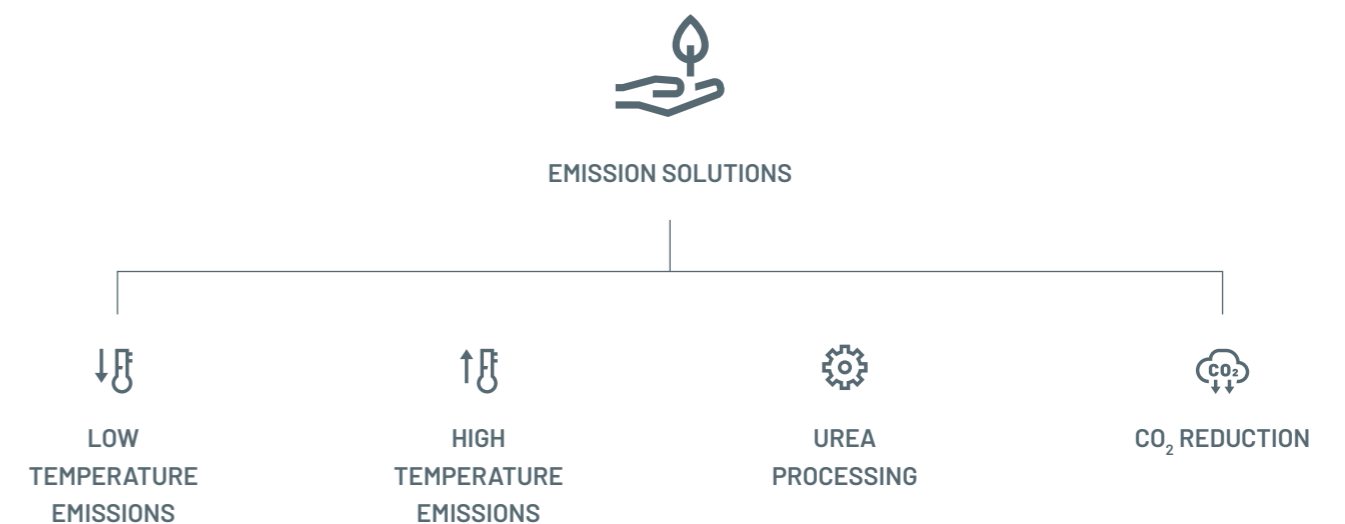

EHC LAMELLA HEATER

TECHNICAL DATA

Emission reduction:

- Up to 90 % of NO_x emissions

Vehicle applications:

- Passenger cars: Diesel / gasoline / hybrid
- Commercial vehicles: Diesel / gasoline / hybrid

On-board system network:

- 48 V
- 400 V optional

Heating capacity:

- Up to 6.5 kW at 48 V

Catalytic converter applications:

- Ceramic
- Metal

New approaches and concepts are now required, due to a further reduction of emission values in the wake of future legislation. In this context, the engine cold-start phase, in which a large proportion of pollutant emissions occur, is of particular importance. The EHC Lamella Heater from Purem by Eberspächer is the first product in the innovative Active Heating product family. It brings the catalytic converters to operating temperature more quickly, while sustainably increasing the efficiency of exhaust gas purification.

The Purem by Eberspächer EHC Lamella Heater is an electric heating catalytic converter that guides the exhaust gas flow over electrically preheated lamellas at the inlet of the exhaust system. In diesel and gasoline-powered vehicles, it is installed directly in front of the catalytic converters. Using diesel as an example, NO_x emissions are reduced by up to 90 percent by earlier activation of the SCR system. If required, the EHC Lamella Heater heats up the exhaust gas purification system even before the engine is started, thereby increasing the efficiency of the exhaust gas purification system right from the beginning of the journey.



BENEFITS

- Insulated high-temperature heating element
- Non-live component
- Lamella surface for high heat transfer into the exhaust gas (optional catalytic coating)
- Preheat function (even without secondary air)
- Scalability
- Flexible contacting position

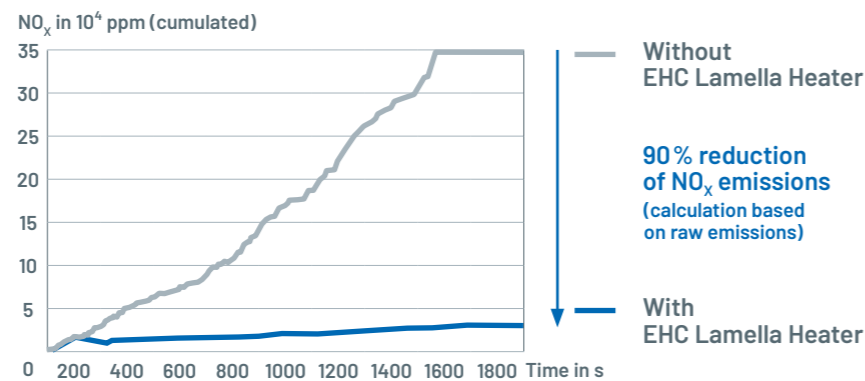

MATURITY AND TIMELINE (as of 04/2022)

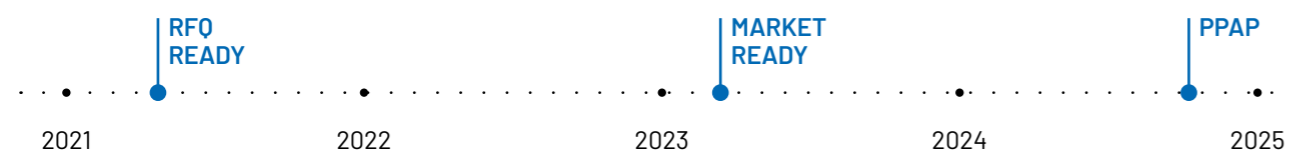

EHC FRACTAL HEATER

The EHC Fractal Heater is part of the Active Heating product family. It is suitable for exhaust gas aftertreatment in diesel and gasoline-powered vehicles with 48 V power supply.

The EHC Fractal Heater increases the efficiency of exhaust gas cleaning in the cold-start phase as well as in the low-load range. Installed at the inlet of the exhaust gas purification system, the exhaust gas flows over the fractal heating elements and heats the component after a very short time. This enables rapid energy and heat transfer to the downstream catalytic converter. If required, it heats the exhaust system even before the engine is started. Shortly after driving begins, pollutant emissions in the exhaust gas mixture are reduced by up to 90 percent, as confirmed under applicable test conditions.



TECHNICAL DATA

Emission reduction:

- Up to 90 % of NO_x emissions

Vehicle applications:

- Passenger cars: Diesel / gasoline / hybrid
- Commercial vehicles: Diesel / gasoline / hybrid

On-board system network:

- 48 V

Heating power:

- Scalable up to 14 kW at 48 V

Catalytic converter applications:

- Ceramic
- Metal

BENEFITS

- Fractal heating element
- Fast heating
- Large heating surface
- Highly flexible
- Preheat function
- High and fast scalability
- Flexible contacting position

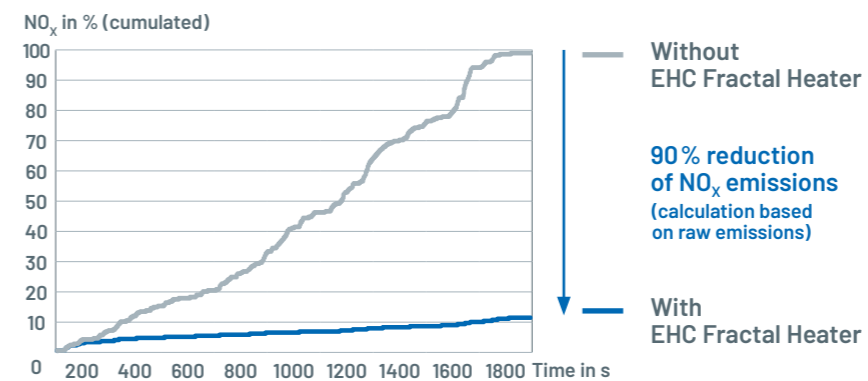

MATURITY AND TIMELINE (as of 04/2022)



HEATED TUNNEL MIXER

TECHNICAL DATA

Emission reduction:

- Up to 70% of NO_x emissions

Vehicle applications:

- Diesel
- Diesel hybrid

On-board system network:

- 12 V
- 48 V optional

Heating power:

- ~ 500 W

BENEFITS

- Applicable to different mixer geometries
- Improved NH₃ conversion rate
- Reduction of deposits

Efficiency improvements are needed in the SCR system of modern diesel and diesel hybrid vehicles – especially in the cold-start phase.

The heated tunnel mixer is a further development of the CLEPA award-winning Purem by Eberspächer tunnel mixer. The system ensures optimum preparation of AdBlue®, which contributes to an improved NH₃ conversion rate. As a result, nitrogen oxide reductions of up to 70 percent can be achieved.

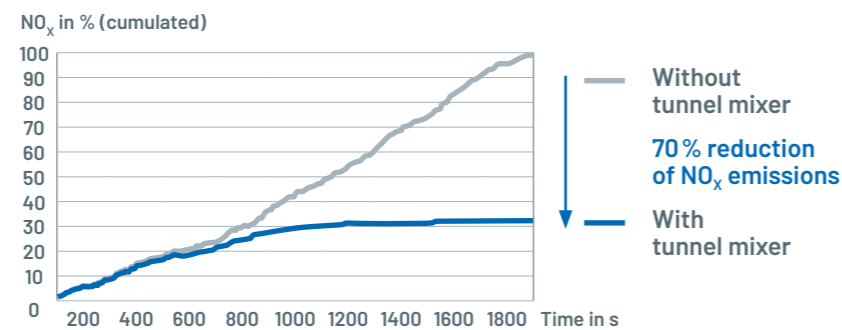

MATURITY AND TIMELINE (as of 04/2022)

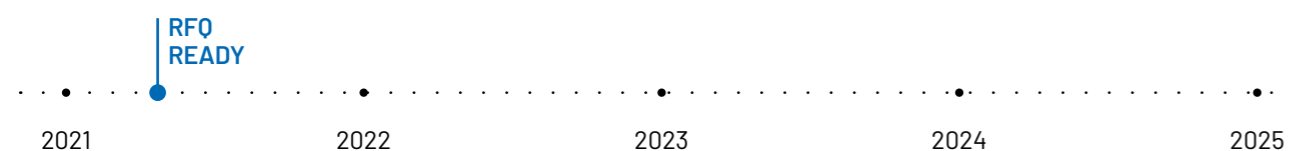

GENERATION 2 EMISSION VALVE – EVG2

Certain operating conditions require a back pressure in the exhaust system. In the case of exhaust gas recirculation, this back pressure is required to return the exhaust gases to the air intake system via a bypass. In this and other applications, the EVG2 emission valve enables the optimum back pressure to be built up.

The valve is typically positioned behind the exhaust gas cleaning system in the cold end. Compared to its predecessor, the second generation has a significantly increased switchable back pressure. It is more lightweight and has a higher maximum temperature. The EVG2 can flexibly respond to different application and customer requirements.

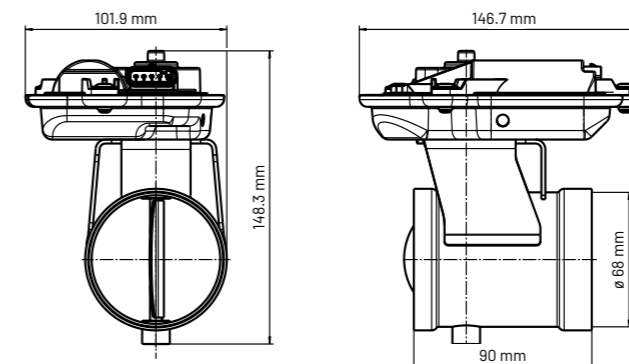

TECHNICAL DATA

Connection diameter:

- Ø 68 mm

Weight:

- ~ 900 g

Temperature management:

- Exhaust gas temperature: 650 °C
- Actuator temperature: -40 °C up to +140 °C

Switchable back pressure:

- 600 mbar

External leakage:

- 10 l/min at 300 mbar

Switching cycles:

- 10,000,000 operations

Actuators:

- Smart
- Non-Smart

Fail-safe functionality:

- Yes

Response time:

- Opening: 250 ms
- Closing: 300 ms

Input signal:

- PWM (optional LIN & CAN)

BENEFITS

- Back pressure generation
- Variable actuator positioning
- Generic product for different applications

MATURITY AND TIMELINE (as of 04/2022)

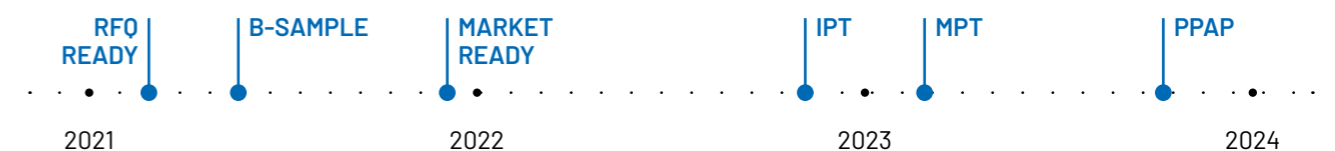

HEAT EXCHANGER

TECHNICAL DATA

Dimensions:

- Length: 164 mm
- Width: 135 mm
- Height: 133 mm

Vehicle applications:

- Gasoline plug-in hybrids (PHEV)
- Gasoline full-hybrids (FHEV)

Heat recovery capacity:

- 2.8 kW (closed valve)

Heat dissipation capacity:

- Max. 1.4 kW (open valve)

BENEFITS

- The most compact design on the market
- The most lightweight product on the market, weighing only 2.2 kg
- Approved for CO₂ credits (EPA)
- Purem by Eberspächer system integration
- Reduced fuel consumption due to early heating of the combustion engine
- Faster heating of the vehicle cabin

Impending fleet consumption targets set by vehicle manufacturers call for technical solutions to further reduce CO₂ emissions. Heat recovery from exhaust gases plays an important role in supporting faster engine warm-up. This leads to lower fuel consumption and improved heating of the vehicle cabin. Heat exchangers are mainly used in plug-in hybrid vehicles (PHEV) and full hybrid vehicles (FHEV) with gasoline engines. In order to develop a product that meets even the highest demands, Purem by Eberspächer and Japanese heat exchanger specialist Sango have formed a strategic partnership.

The Heat Exchanger not only excels with its compact design, it is also the most lightweight product on the market, weighing just 2.2 kg.

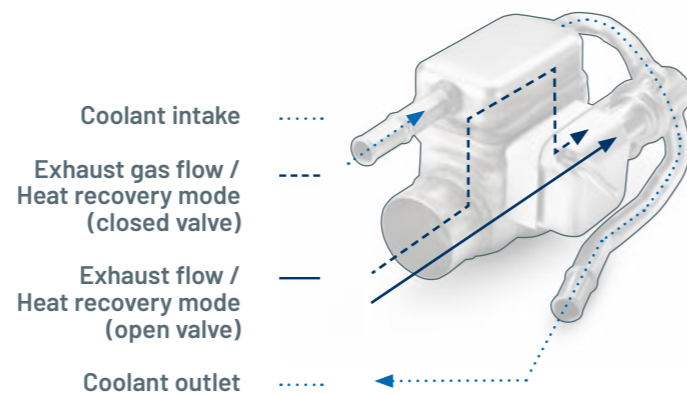

MATURITY AND TIMELINE

 In series production since 2019

THIN-WALL INSULATION

Efficient exhaust gas aftertreatment calls for sophisticated thermal management. The objective is to reduce thermal losses in the exhaust system. Thin-wall insulation provides additional cladding for exhaust gas components. It consists of a thermal insulation material and a thin-walled metallic support shell, thereby ensuring heat retention in the system. Thin-wall insulation from Purem by Eberspächer can be produced with a wall thickness of 0.4 mm or less, thereby contributing to vehicle weight reduction.

In addition, insulation serves as a heat shield for heat-sensitive components such as sensors, batteries and starters, which without protection could be negatively impacted in their function.

TECHNICAL DATA

Wall thickness:

- < 0.4 mm

BENEFITS

- Heat preservation in the exhaust system
- Positive acoustic effects
- Lightweight solution due to thin-wall thickness
- Heat protection for surrounding components due to reduced surface temperatures

Supporting:

- Catalytic converter light-off
- Particle filter regeneration
- AdBlue® evaporation



MATURITY AND TIMELINE

 In series production since 2021

COMPACT MIXING ELEMENTS FOR COMMERCIAL VEHICLES

TECHNICAL DATA

Vehicle applications:

- Commercial vehicles ($\lambda > 1$)*
- Agricultural and work machinery ($\lambda > 1$)*

BENEFITS

- Component scalable depending on installation space and engine requirements
- Low weight
- Extended mixing path
- Optimum urea preparation for high NO_x conversion rates in all operating ranges
- Reduced deposit formation
- High flexibility in the package due to modular design
- Installation possible both vertically and horizontally
- High ease of maintenance

* Diesel and gas in lean operation

Current and future emission legislation requires highly efficient systems to reduce NO_x. With the first-generation Compact Mixer, Purem by Eberspächer has developed a solution to achieve high-performance AdBlue® preparation in the smallest possible installation space. Only with the optimal provision of NH₃ can a high nitrogen oxide conversion be guaranteed in all operating ranges at the downstream SCR catalytic converter.

One of Purem by Eberspächer's strengths is its local development centers, which design, validate and industrialize products specifically for local markets. This enables Purem by Eberspächer to respond quickly and efficiently to specific market requirements. The Low Urea Deposit Mixer is an independent local development by Purem by Eberspächer China for the Asian market.



Compact Urea Processing Unit



Low Urea Deposit Mixer

MATURITY AND TIMELINE (as of 04/2022)

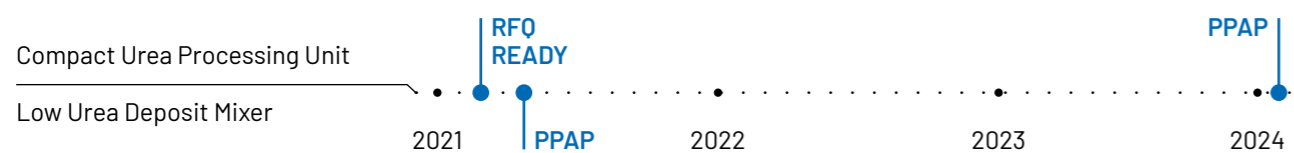

CANNING OVAL SUBSTRATES IN COMMERCIAL VEHICLES

Accommodating large-volume substrates for exhaust gas aftertreatment components presents a special challenge in commercial vehicles. With oval catalytic converters or filters, existing installation space can be optimally used and the intake flow can be improved. This is why Purem by Eberspächer has developed a solution for embedding large-volume substrates with an oval cross-section in the exhaust pipe. Until now, only catalytic converters with circular cross-sectional areas were used in the commercial vehicle segment.

BENEFITS

- Reduced space requirement for the exhaust gas cleaning box with the same substrate volume
- Reduction of back pressure
- Greater design freedom

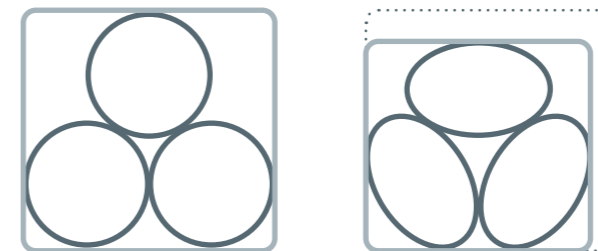

Size reduction of the exhaust gas cleaning box with the same substrate volume

MATURITY AND TIMELINE (as of 04/2022)

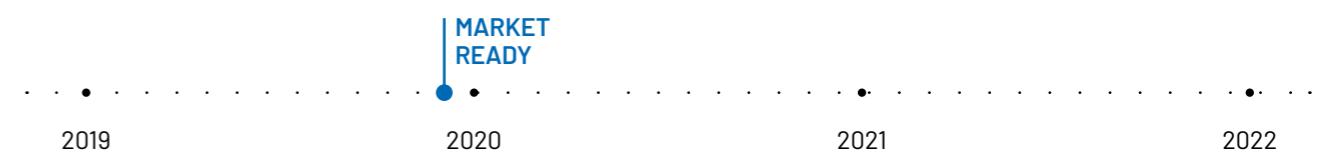



ACOUSTIC SOLUTIONS – THE FUTURE WILL BE QUIET

Environmental protection, noise perception and new vehicle concepts are the challenges facing tomorrow's acoustic world. Increasingly strict legislation is also calling for innovative approaches to solutions. In Europe, for example, the limit for noise emissions is being lowered by an average of 2 dB(A) in four-year steps. Keep in mind that a reduction of 3 dB(A) implies a halving of acoustic power.

Within the framework of these trends and specifications, Pures by Eberspächer is working on advanced solutions in the field of acoustics specifically in the three following technological areas: Muffler Systems, Acoustic Valves and Active Noise Cancellation.

These approaches are reflected in the Pures by Eberspächer product portfolio. Previously purely passive muffler systems are now becoming active. Through the development of valves, Pures by Eberspächer now also manufactures products with moving components – even mechatronic systems in the case of active valves. Pures by Eberspächer has the expertise required to meet these requirements entirely in house.

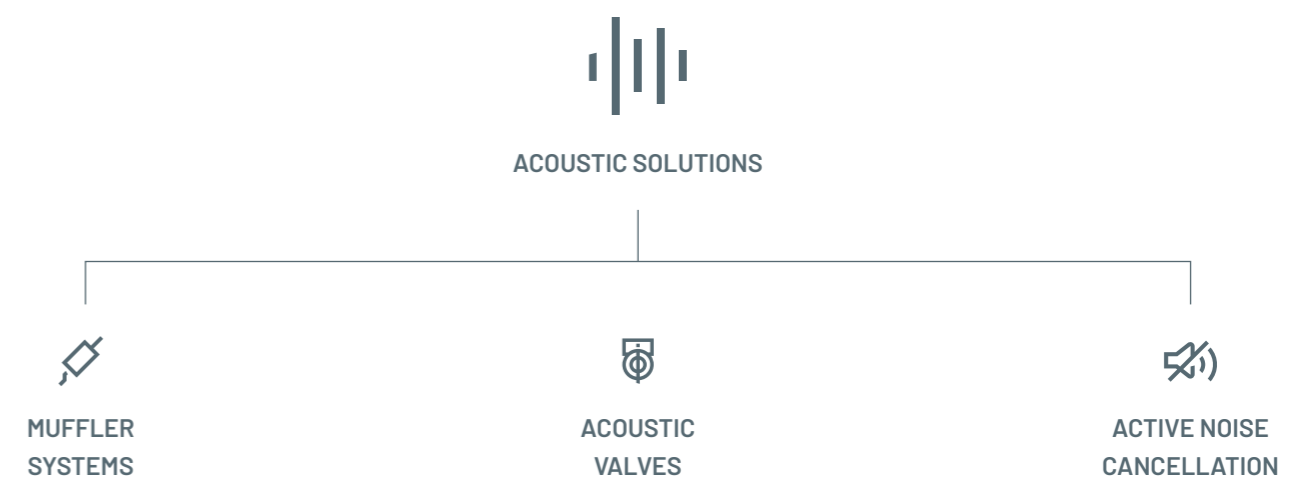

GENERATION 2 ACOUSTIC VALVE – AVG2

TECHNICAL DATA

Dimensions:

- Height: 143 mm
- Housing width: 40 mm
- Weight: 570 g

Connection diameters:

- Ø 55 mm
- Ø 65 mm
- Ø 75 mm

Input signal:

- PWM or LIN

Protection class:

- IP6K9K and IPx7 in accordance with ISO 20653

Positionierung:

- Continuously adjustable: 0–90°
- Positioning accuracy: +/- 2°

BENEFITS

Acoustic performance:

- Acoustically tight
- Advanced design: minimized gap and tolerances

Temperature management:

- Exhaust gas temperature: 750 °C
- Actuator temperature: -40 °C up to +140 °C

Endurance:

- 2,000,000 end strokes
- 3,000,000 switching operations

Optional:

- Heat shield plate for AVG2 (protection of the actuator against heat and contamination)

The second-generation acoustic valve (AVG2) was developed to reduce noise and back pressure, especially with reduced silencer volume. Thanks to maximum acoustic tightness, lower noise emissions with pleasing vehicle sound are achieved. This is accomplished by an electrically driven and adjustable orifice that continuously opens and closes flow paths in the exhaust system.

Compared with the previous model, the second generation features significantly improved acoustics. It is more lightweight and has a higher permissible maximum temperature. A special feature: From development to testing to production, the new acoustic valve is entirely from Purem by Eberspächer for the first time.



Variant with heat shielding plate

AVG2 compared to AVG1

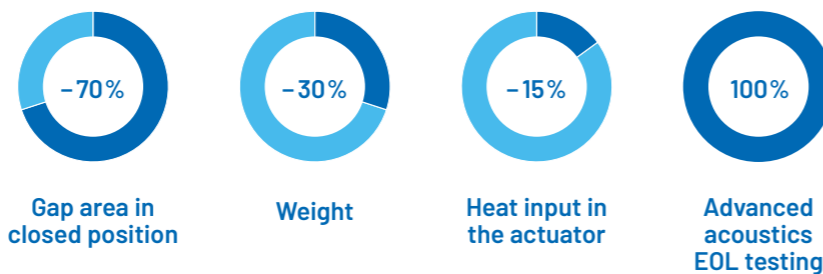

MATURITY AND TIMELINE

In series production since 2020

PASSIVE VALVES

The passive valve is integrated into the silencer. It achieves higher sound insulation with the same silencer volume. By design, the silencer volume can be reduced by up to 25 percent if required.

The insulation effect remains virtually the same. The valve moves against a defined spring force due to the pressure of the exhaust gas mass flow.

Passive valves represent a cost-effective approach to sound design. They can be attached to a pipe end or a muffler base. This allows Purem by Eberspächer to design and manufacture silencers more flexibly.

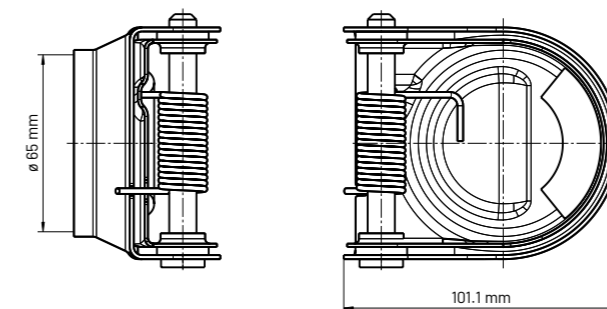

TECHNICAL DATA

Weight:

- 320 g

Connection diameter:

- Ø 65 mm
- Ø 55 mm

Material:

- Premium variant: stamped - SS441 / Spring - Waspaloy
- Economy variant: stamped - SS409 / Spring - DHN 2661

Exhaust gas temperature:

- Premium variant: up to 700 °C
- Economy variant: up to 500 °C

Maximum opening:

- No mechanical stop
- Test determined 20° opening angle at 300 scfm

Durability:

- 300,000 opening cycles at 700 °C
- 1,200,000 opening cycles at 650 °C

BENEFITS

Additional sound insulation:

- Up to -5 dB

Reduction in sound insulation volume:

- Up to 25%

MATURITY AND TIMELINE

In series production since 2020

MAIN SITES AND PLANTS



EUROPE

- | | | | | |
|-----------------------------------------|----------------------------|-----------|---------------------------------|----------------|
| Headquarters and R&D | FRANCE | AUSTRIA | RUSSIA | CZECH REPUBLIC |
| ● Esslingen | ● Maubeuge
● St. Michel | ● Graz | ● St. Petersburg
● Togliatti | ● Rakovnik |
| Plants | ITALY | PORTUGAL | SWEDEN | |
| GERMANY | ● Castellalto | ● Tondela | ● Nyköping | |
| ● Emden
● Neunkirchen
● Wilsdruff | NETHERLANDS | ROMANIA | SLOVAK REPUBLIC | |
| ENGLAND | ● Sittard | ● Oradea | ● Nitra | |
| ● Cowley | | | | |

AMERICA

- | | |
|---------------------------------|-------------------------------------------------------------------------------------------|
| Headquarters and R&D | NORTH AMERICA |
| ● Novi, MI | ● Brighton, MI
● Louisville, KY
● Northport, AL
● Spartanburg, SC
● Wixom, MI |
| Plants | |
| BRAZIL | |
| ● Resende
● Sorocaba | |
| MEXICO | |
| ● Ramos Arizpe | |

AFRICA / ASIA

- | | |
|----------------------------------------------------------------------|-------------------------------------|
| Headquarters and R&D | INDIA |
| ● Shanghai | ● Xí'an
● Yulin
● Zhangjiakou |
| Plants | |
| CHINA | |
| ● Changchun
● Chongqing
● Guangzhou
● Shenyang
● Taizhou | |
| | SOUTH AFRICA |
| | ● Port Elizabeth
● Rosslyn |

LEGEND

- Headquarters and R&D
- Technology plant
- JIS plant
- Joint Venture

PUREM GMBH
EBERSPÄCHERSTRASSE 24
73730 ESSELINGEN / GERMANY

PHONE: +49 711 939-00
FAX: +49 711 939-0634
info@eberspaecher.com
www.eberspaecher.com
www.purem.com